

421

INDEX NO.

CAULKER

APPLICATION

Waterworks systems, wastewater and other liquids chemically neutral. Intended for connection or repairs of leaking joints of socket cast iron pipes.

DESIGN FEATURES

- diameter range DN50-DN600
- body - ductile iron EN GJS-500-7
- EPDM or NBR seal
- standard connecting bolts - galvanised, stainless steel bolts also available
- anticorrosion coating - epoxy RAL5005, min. 250 µm

TECHNICAL DATA / STANDARDS

- material acc. PN-EN 1563
- seal acc. PN-EN 681-1
- nominal pressure: PN16
- temperature range:
 - EPDM: -10°C / +70°C
 - NBR: -20°C / +80°C

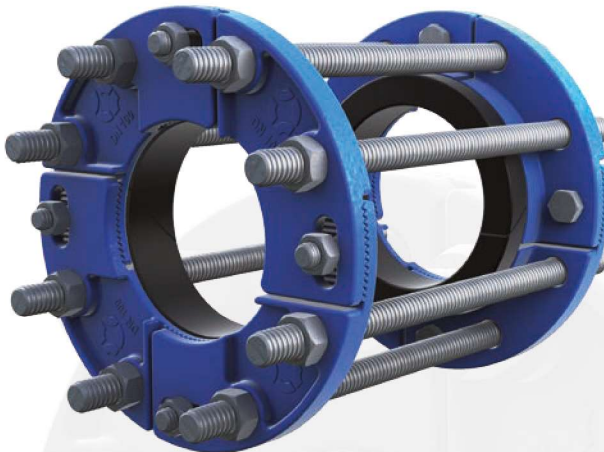
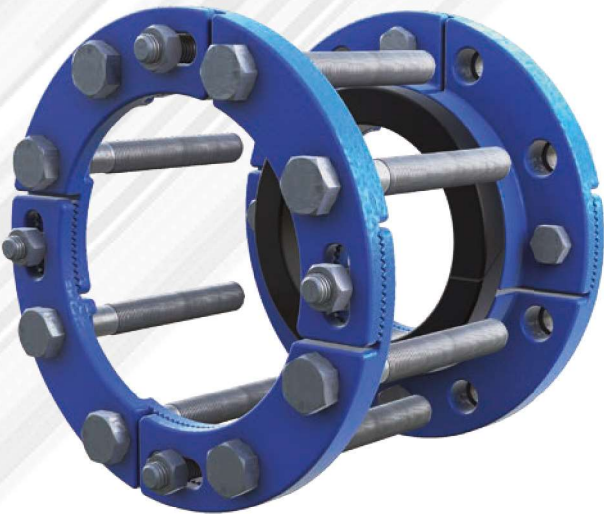

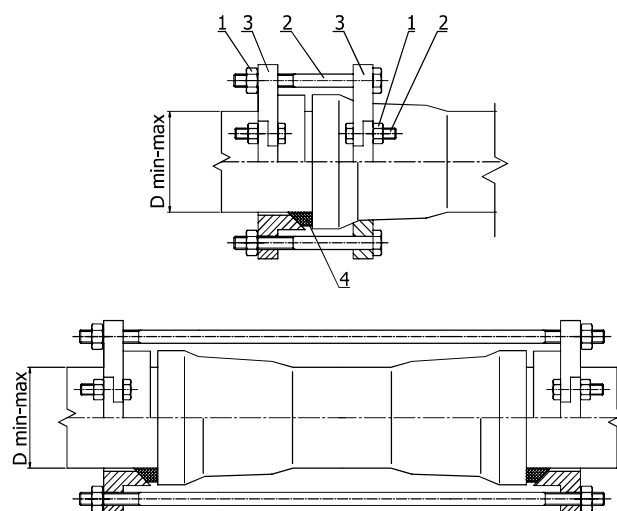

No.	Part	Material	Standard
1	Nut	S235JR / Zn5	PN-EN ISO 4032
2	Bolt	S235JR / Zn5	PN-EN ISO 4017
3	Body	EN GJS-500-7	PN-EN 1563
4	Seal	EPDM or NBR	PN-EN 681-1

DN	Diameter range	Weight [kg]
	Dmin-max [mm]	
50	62 - 68	3,3
65	75 - 84	4,3
80	94 - 100	8,5
100	114 - 120	9,1
150	166 - 173	11,2
200	217 - 224	13,4
250	270 - 276	18,2
300	321 - 328	19,6
350	373 - 380	27,0
400	424 - 431	30,4
500	527 - 534	37,2
600	630 - 638	50,0